



DAVINCI TECHNICAL DATA GUIDE

# NOOZLE CHECK VALVES

## FLANGED ENDS

Ref. 167A-LA / PN 10-16



### Application

Clean and pre-treated water  
Wastewater and sewage systems  
Fire protection systems  
Irrigation networks  
Cooling water circuits  
HVAC installations  
Marine systems  
Oil and Gas pipelines  
Chemical Processing

### Approvals/Standards

Face to Face: EN 558-1 Series 14 F4  
Mounting between flanges: PN10/16 EN 1092-2, ISO 7005-2.  
Pressure Tests acc. to EN 12266-1 Rate A. GB/T13927-1992  
Pressure Tests: Body: 1,5 x PN. Seat: 1,1 x PN  
EU directive 2014/68/EU:  
Products excluded, article 1, § 2b up to DN300. Risk Category I MoD. A from DN350 to DN600

### Certifications

CE, WRAS

### Range

DN50-1200, PN10-16-25





## GENERAL CHARACTERISTICS

Sizes DN50 to DN1200.  
Durable and low weight body.  
Low headloss.  
Closing speed up to 0.2 sec.  
Vertical, horizontal & inclined installation.  
WRAS epoxy paint 250 microns.

## WORKING CONDITIONS

Pressure ratings: 1.0 Mpa, 1.6 Mpa, 2.5 Mpa.  
Working temperature: -10°C + 95°C.  
Flow media: Clean water.

Nº	ITEM	MATERIAL
1	Body	GJS500-7
2	Disc	GJS500-7 + EPDM
3	Spring	AISI304 / AISI316
4	Stem	AISI420 / AISI304 / AISI316
5	Washer	EPDM
6	Nut	AISI420 / AISI304
7	Bushing	C61900
8	Diffuser	GJS500-7
9	Set screw	AISI304
	RAL 5015 Painting	Epoxy 250 µm

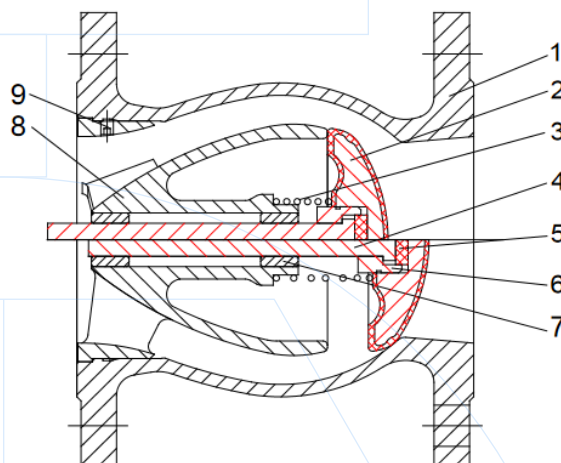

Components may be replaced with materials of equivalent or superior grade without prior notice, in accordance with our continuous improvement policy.

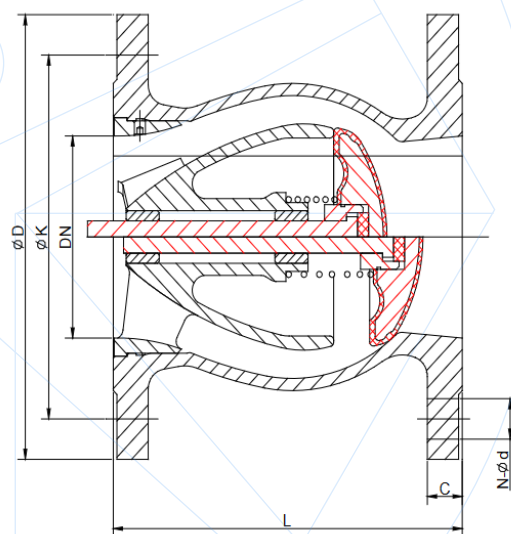
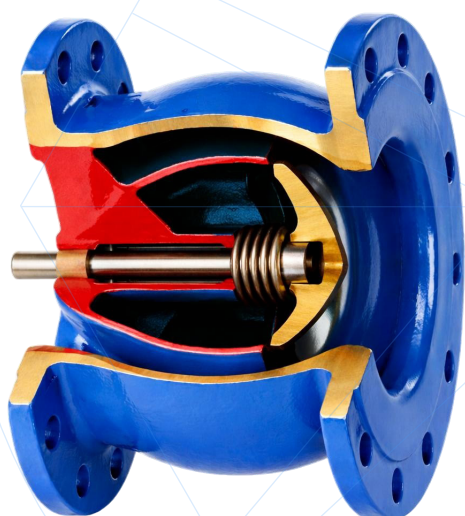

DN	L	D			K			n-Ød			C		Weight (kg)		
		PN10	PN16	PN25	PN10	PN16	PN25	PN10	PN16	PN25	PN10	PN16	PN25	PN10/16	PN25
50	150		165			125			4-19			19		6.2	6.2
65	170		185			145		4-19	8-19			19		9.1	9.1
80	180		200			160		8-19	8-19			19		11.3	11.3
100	190	220		235	180		190	8-19	8-23			19		14.5	15.1
125	200	250		270	210		220	8-19	8-28			19	23.5	18.3	19.0
150	210	285		300	240		250	8-23	8-28			19	26	25.5	26.8
200	230	340		360	295		310	8-23	12-23	12-31		20	30	38.5	40.5
250	250	395		405	350		355	12-23	12-28	16-34		22	34.5	57.0	59.9
300	270	445		460	400		410	12-23	12-28	16-34		24.5	39.5	73.0	76.3
350	290	505		520	460		470	16-23	16-28	16-37		26.5	44	109.0	128.0



N°	ITEM	MATERIAL
1	Body	GJS500-7
2	Disc	GJS500-7 + EPDM
3	Spring	AISI304 / AISI316
4	Stem	AISI420 / AISI304 / AISI316
5	Washer	EPDM
6	Nut	AISI420 / AISI304
7	Bushing	C61900
8	Plug	GJS500-7
9	Diffuser	GJS500-7
10	Set screw	AISI304
	RAL 5015 Painting	Epoxy 250 µm

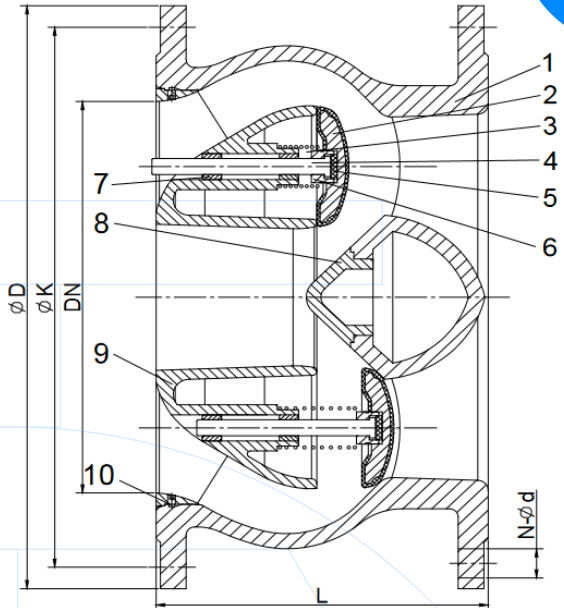

DN	L	D			K			n-Ød			C			Weight (kg)	
		PN10	PN16	PN25	PN10	PN16	PN25	PN10	PN16	PN25	PN10	PN16	PN25	PN10/16	PN25
400	310	565	580	620	515	525	550	16-28	16-31	16-41	24,5	24,5	48	145	154
450	330	615	640	670	565	585	600	20-28	20-31	20-41	25,5	25,5	49	168	192
500	350	670	715	730	620	650	660	20-28	20-34	20-44	26,5	26,5	52	235	255
600	390	780	840	845	725	770	770	20-31	20-37	20-50	30	30	58	346	366
700	430	910	910	960	840	840	875	24-31	24-37	24-43	39,5	39,5	46,5	480	544
800	470	1025	1025	1085	950	950	990	24-34	24-40	24-49	43	43	51	604	723
900	510	1125	1125	1185	1050	1050	1090	28-34	28-40	28-49	46,5	46,5	55,5	850	947
1000	550	1230	1255	1320	1160	1170	1210	28-37	28-43	28-56	40	50	60	1270	1414
1200	630	1455	1485	1530	1380	1390	1420	32-40	32-49	32-56	45	57	69	1680	1950

**HEAD LOSS CURVE**

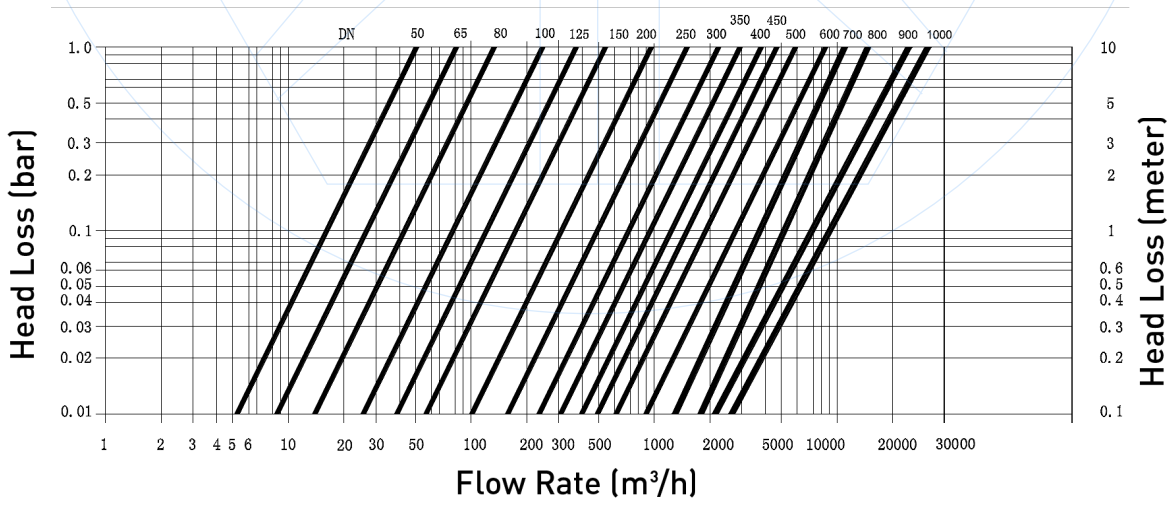



CONTACT US

# DAVINCI VALVES ORDER REQUEST

Ref. 167A-LA / PN 10-16-25

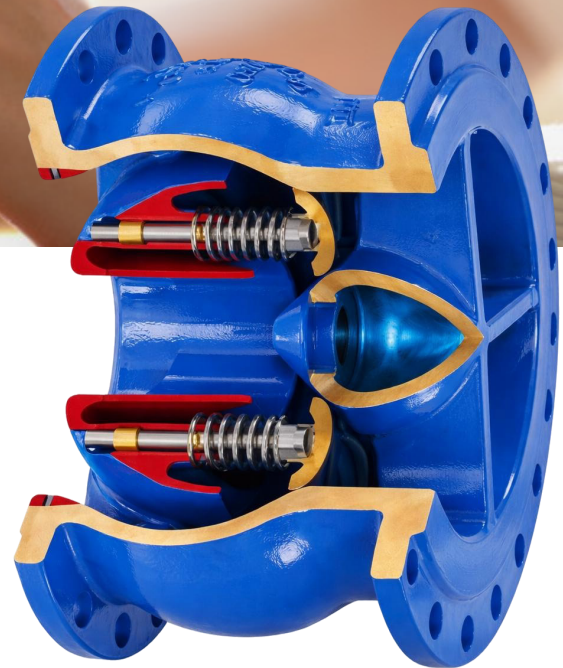

## Head Office CHENGDU

Room 3208 Unit 1 Building 1,  
No. 6 Zhiquan Section, Dongda Street  
Jinjiang District, Chengdu, Sichuan  
CHINA

+86 17340168233 +86 19302892712  
valves@davincivalves.com

Europe Office MADRID  
SPAIN  
zuzana@davincivalves.com

## WEBSITE

davincivalves.com

YOUR QUALITY WATER PROJECTS PARTNER  
For professionals who look for more.