



DAVINCI TECHNICAL DATA GUIDE

# RESILIENT SEAT GATE VALVE

## THREADED ENDS

Ref. 123B-VI / PN 10-16



### Application

Drinking water distribution.  
Pumping installations.  
Sewage and irrigation systems

### Approvals/Standards

Design acc. to DIN 3352  
Face to face acc. to GB/T12221-2015  
Thread ends GS/NPT.  
Pressure Tests acc. to EN 12266-1 Rate A.  
Pressure Tests: Body: 1,5 x PN, seat: 1,1 x PN.

### Certifications

CE, WRAS

### Range

DN20-50, PN10-16



## GENERAL CHARACTERISTICS

Sizes DN20 to DN50.  
 Working pressure PN10/16.  
 WRAS certificate (rubber and paint) for drinking water  
 100% tightness in both ways. Full bore.  
 Repackable under pipeline pressure.  
 Complies with EN 1074-2 specifications.  
 Low torque values.  
 WRAS epoxy paint 250 microns.

## WORKING CONDITIONS

Pressure ratings: 1.6 Mpa.  
 Working temperature: -10°C + 90°C

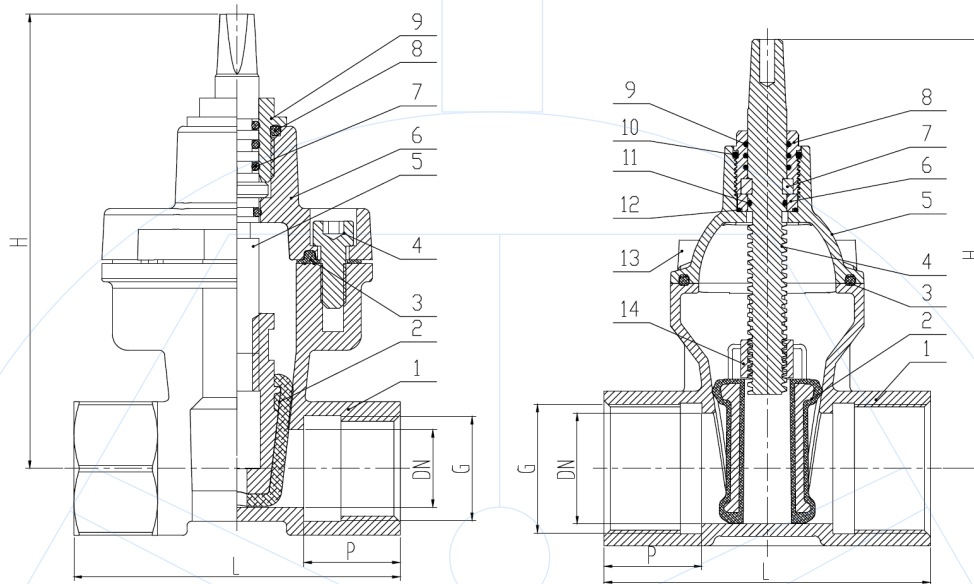

*Components may be replaced with materials of equivalent or superior grade without prior notice, in accordance with our continuous improvement policy.*

Nº	ITEM	MATERIAL
1	Body	GJS500-7
2	Disc	GJS500-7 + EPDM (DN40/50) Brass+ EPDM (DN20/25/32)
3	Bonnet gasket	NBR
4	Stem	AISI 304
5	Bonnet	GJS500-7
6	Thrust washer	Brass
7	Thrust	Brass
8	Thrust nut	Brass
9	O-ring	NBR
10	O-ring	NBR
11	O-ring	NBR
12	O-ring	NBR
13	Bolts	A2
14	Stem nut	Brass
	RAL 5015 Painting	Epoxy 250 µm

DN	L	H	G	P	Torque (N·m)	Weight (kg)
20	95	145	3/4"	27	15	2,34
25	105	145	1"	30	15	2,85
32	120	150	1 1/4"	32	15	3,4
40	130	202	1 1/2"	37	30	3,95
50	150	197	2"	45	30	4,35



CONTACT US

# DAVINCI VALVES ORDER REQUEST



## Head Office CHENGDU

Room 3208 Unit 1 Building 1,  
No. 6 Zhiquan Section, Dongda Street  
Jinjiang District, Chengdu, Sichuan  
CHINA

+86 17340168233 +86 19302892712  
valves@davincivalves.com

Europe Office MADRID  
SPAIN  
zuzana@davincivalves.com

## WEBSITE

davincivalves.com



YOUR QUALITY WATER PROJECTS PARTNER  
For professionals who look for more.